

AMMBTA55-HF (PNP)

RoHS Device
Halogen Free

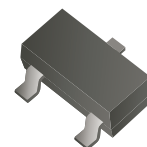

Features

- Epitaxial planar die construction.
- High conductance.
- AEC-Q101 Qualified.

Mechanical data

- Case: SOT-23, molded plastic.
- Mounting position: Any.

Circuit Diagram

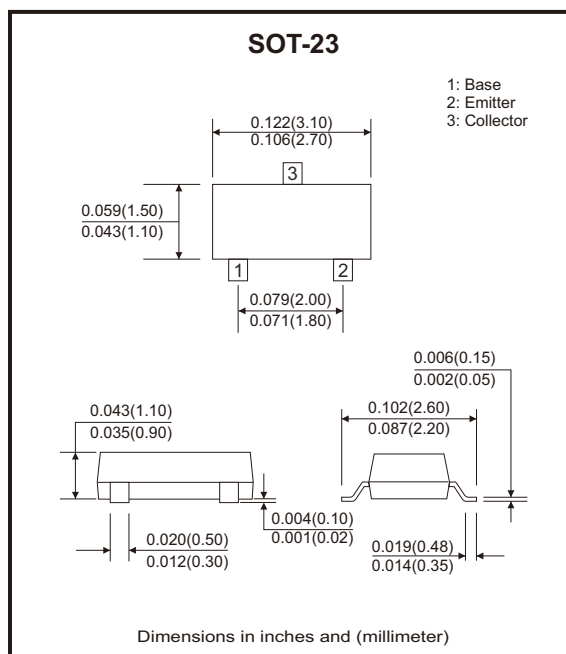
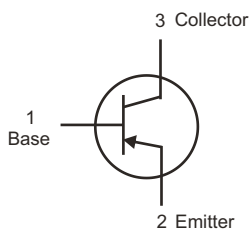

Maximum Ratings (at Ta=25°C unless otherwise noted)

Parameter	Symbol	Value	Units
Collector-base voltage	V _{CBO}	-60	V
Collector-emitter voltage	V _{CEO}	-60	V
Emitter-base voltage	V _{EBO}	-4	V
Collector current (DC)	I _C	-0.5	A
Base current	I _B	-0.2	A
Collector dissipation	P _C	0.35	W
Thermal resistance, junction to ambient	R _{θJA}	417	°C/W
Thermal resistance, junction to case	R _{θJC}	142	°C/W
Junction and storage temperature	T _J , T _{STG}	-55 to +150	°C

Electrical Characteristics (at $T_a=25^\circ\text{C}$ unless otherwise noted)

Parameter	Conditions	Symbol	Min	Typ	Max	Units
Collector-base breakdown voltage	$I_C = -100\mu\text{A}, I_E = 0$	$V_{(BR)CBO}$	-60			V
Collector-emitter breakdown voltage	$I_C = -1.0\text{mA}, I_B = 0$	$V_{(BR)CEO}$	-60			V
Emitter-base breakdown voltage	$I_E = -100\mu\text{A}, I_C = 0$	$V_{(BR)EBO}$	-4			V
Collector cut-off current	$I_E = 0, V_{CB} = -60\text{V}$	I_{CBO}			-0.1	μA
Collector cut-off current	$I_B = 0, V_{CE} = -60\text{V}$	I_{CES}			-0.1	μA
DC current gain	$V_{CE} = -1\text{V}, I_C = -10\text{mA}$	h_{FE}	100			
	$V_{CE} = -1\text{V}, I_C = -100\text{mA}$	h_{FE}	100			
Collector-emitter saturation voltage	$I_C = -100\text{mA}, I_B = -10\text{mA}$	$V_{CE(sat)}$			-0.25	V
Base-emitter saturation voltage	$I_C = -100\text{mA}, V_{CE} = -1\text{V}$	$V_{BE(on)}$			-1.2	V
Transition frequency	$I_C = -100\text{mA}, V_{CE} = -1\text{V}, f = 100\text{MHz}$	f_T	50			MHz

Rating and Characteristic Curves (AMMBTA55-HF)

Fig.1 - Static Characteristic

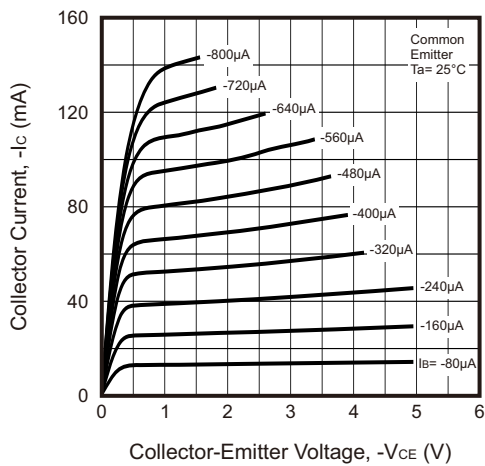

Fig.2 - $h_{FE} - I_C$

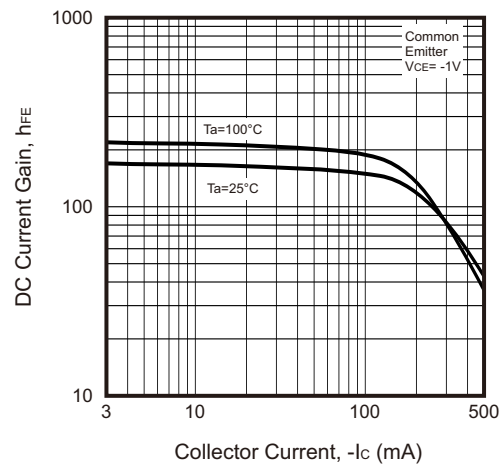

Fig.3 - $V_{CEsat} - I_C$

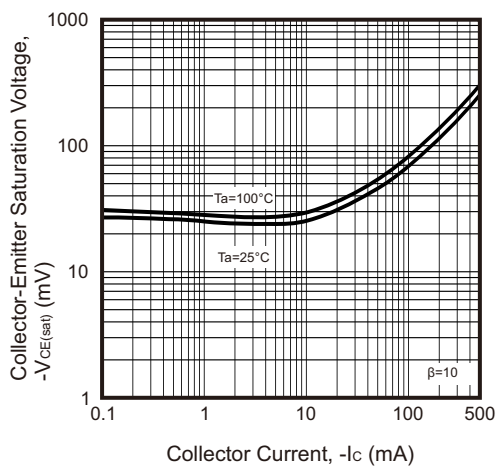
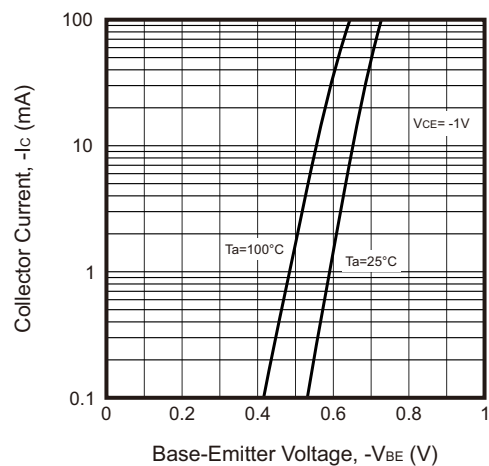
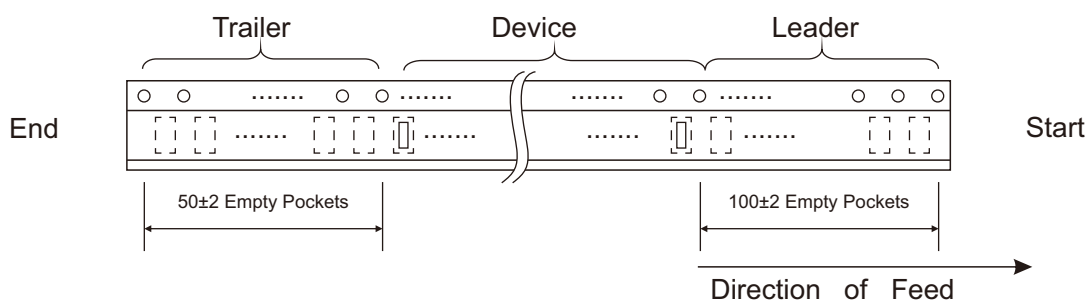
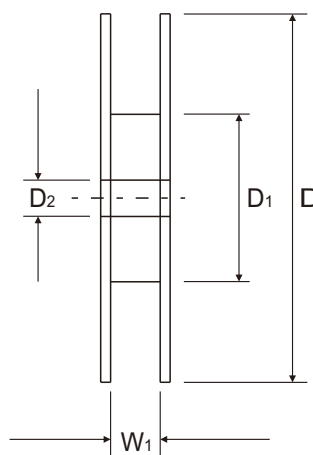
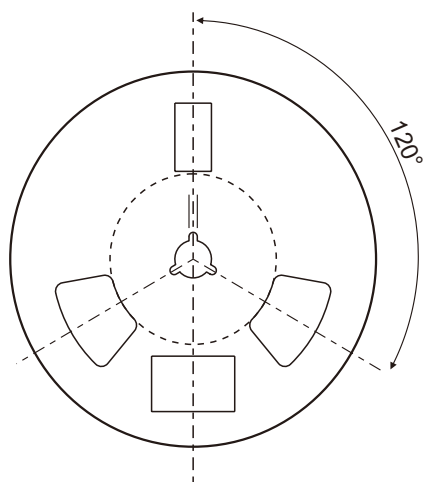
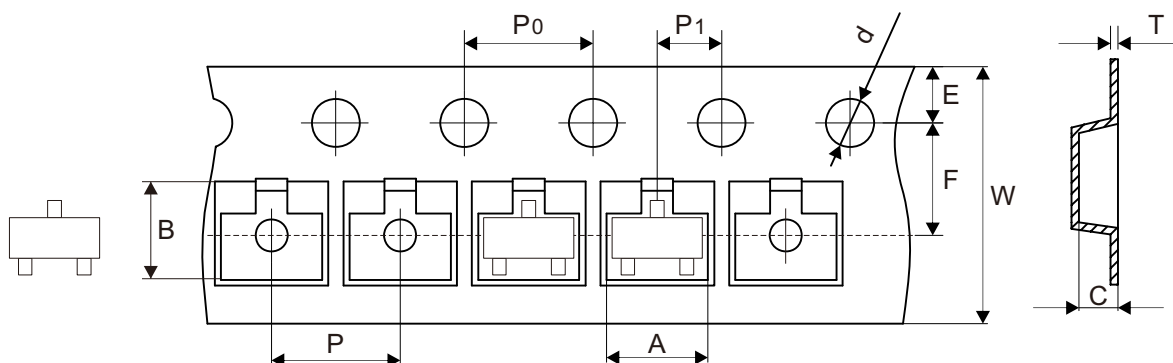

Fig.4 - $V_{BE} - I_C$



Reel Taping Specification



SOT-23	SYMBOL	A	B	C	d	D	D1	D2
	(mm)	3.15 ± 0.10	2.77 ± 0.10	1.22 ± 0.10	1.50 ± 0.10	178.00 ± 1.00	54.00 ± 0.50	13.00 ± 0.50
	(inch)	0.124 ± 0.004	0.109 ± 0.004	0.048 ± 0.004	0.059 ± 0.004	7.008 ± 0.039	2.126 ± 0.020	0.512 ± 0.020

SOT-23	SYMBOL	E	F	P	P0	P1	T	W	W1
	(mm)	1.75 ± 0.10	3.50 ± 0.10	4.00 ± 0.10	4.00 ± 0.10	2.00 ± 0.05	0.20 ± 0.02	8.00 ± 0.30	9.50 ± 1.00
	(inch)	0.069 ± 0.004	0.138 ± 0.004	0.157 ± 0.004	0.157 ± 0.004	0.079 ± 0.002	0.008 ± 0.001	0.315 ± 0.012	0.374 ± 0.039

Marking Code

Part Number	Marking Code
AMMBTA55-HF	2H

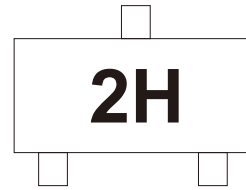

Suggested P.C.B. PAD Layout

SIZE	SOT-23	
	(mm)	(inch)
A	0.90	0.035
B	0.80	0.031
C	0.95	0.037
D	2.00	0.079
E	2.90	0.114

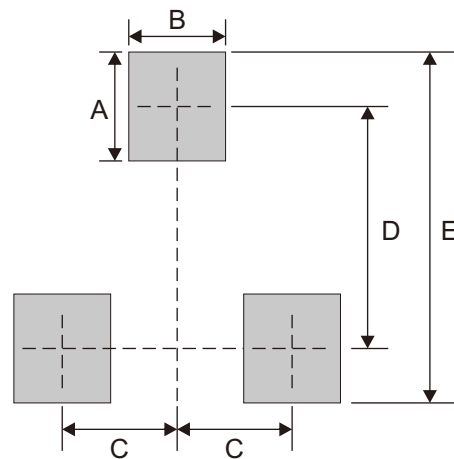

Standard Packaging

Case Type	REEL PACK	
	REEL (pcs)	Reel Size (inch)
SOT-23	3,000	7